

Classification report

Energy economy and heat retention

Test report 421 29133/2e

This is a translation of test report 421 29133/2 dated 16 February 2005



Customer **Guardian Europe S.A.**
Zone Industrielle Wolser

03452 Dudelange
Luxemburg

Basis

EN 673:2000-10 Glass in building – Determination of thermal transmittance (U value)
– Calculation method

Product	Insulating glass unit
System designation	Guardian ClimaGuard™ Premium
	Construction varies, see type list
Construction	4/12-20/4 mm; 4/10-16/4/10-16/4 mm
Gas filling	Air, Argon, Krypton, Ar/SF ₆
Type of coating	low e coating on surface 2 or surface 3 or surface 2+3 or surface 2+5, ($\epsilon_n = 0.03$)

Representation

see figure 1 to figure 4

Instructions for use

This test report may be used to classify the thermal transmittance U_g .

Thermal transmittance



$$U_g = 0.5 \text{ to } 1.6 \text{ W}/(\text{m}^2 \cdot \text{K})^*$$

* value depends on the individual construction (see type list)

Validity

The data and results given relate solely to the described, tested object.

Testing the thermal transmittance does not allow any statement to be made on further characteristics of the present structure which could define performance and quality.

Notes on publication

The ift notice "Notes on the use of ift test reports" applies.

The cover sheet can be used in combination with the type list as a summary.

Contents

The report contains 8 pages in total

- Type list
- 1 Object
- 2 Procedure
- 3 Detailed results

ift Rosenheim
8 March 2005

Ulrich Sieberath
Director



i. V. Norbert Sack
Head Building Physics Department

Type list for insulating glass units Guardian ClimaGuard™ Premium

	Type	Parameters for the calculation					U_g calculated U_g - value according to DIN EN 673 $\Delta T = 15 \text{ K}$ in $\text{W}/(\text{m}^2 \cdot \text{K})$
		construction in mm	filling rate in %	gas type	E^{**}	ϵ_n^*	
1	Guardian ClimaGuard™ Premium	4/12/4	-	Air	2	0.03	1.6
2	Guardian ClimaGuard™ Premium	4/14/4	-	Air	2	0.03	1.5
3	Guardian ClimaGuard™ Premium	4/18/4	-	Air	2	0.03	1.4
4	Guardian ClimaGuard™ Premium	4/20/4	-	Air	2	0.03	1.4
5	Guardian ClimaGuard™ Premium	4/12/4	-	Air	3	0.03	1.6
6	Guardian ClimaGuard™ Premium	4/14/4	-	Air	3	0.03	1.5
7	Guardian ClimaGuard™ Premium	4/16/4	-	Air	3	0.03	1.4
8	Guardian ClimaGuard™ Premium	4/18/4	-	Air	3	0.03	1.4
9	Guardian ClimaGuard™ Premium	4/20/4	-	Air	3	0.03	1.4
10	Guardian ClimaGuard™ Premium	4/12/4	90	Argon	2	0.03	1.3
11	Guardian ClimaGuard™ Premium	4/14/4	90	Argon	2	0.03	1.2
12	Guardian ClimaGuard™ Premium	4/16/4	90	Argon	2	0.03	1.1
13	Guardian ClimaGuard™ Premium	4/18/4	90	Argon	2	0.03	1.1
14	Guardian ClimaGuard™ Premium	4/20/4	90	Argon	2	0.03	1.2
15	Guardian ClimaGuard™ Premium	4/20/4	91	Argon	2	0.03	1.1
16	Guardian ClimaGuard™ Premium	4/12/4	90	Argon	3	0.03	1.3
17	Guardian ClimaGuard™ Premium	4/14/4	90	Argon	3	0.03	1.2
18	Guardian ClimaGuard™ Premium	4/16/4	90	Argon	3	0.03	1.1
19	Guardian ClimaGuard™ Premium	4/18/4	90	Argon	3	0.03	1.1
20	Guardian ClimaGuard™ Premium	4/20/4	90	Argon	3	0.03	1.2
21	Guardian ClimaGuard™ Premium	4/20/4	91	Argon	3	0.03	1.1
22	Guardian ClimaGuard™ Premium	4/10/4	90	Krypton	2	0.03	1.0
23	Guardian ClimaGuard™ Premium	4/12/4	90	Krypton	2	0.03	1.1
24	Guardian ClimaGuard™ Premium	4/16/4	90	Krypton	2	0.03	1.1
25	Guardian ClimaGuard™ Premium	4/10/4	90	Krypton	3	0.03	1.0
26	Guardian ClimaGuard™ Premium	4/12/4	90	Krypton	3	0.03	1.1
27	Guardian ClimaGuard™ Premium	4/16/4	90	Krypton	3	0.03	1.1

	Type	Parameters for the calculation					U_g calculated U_g - value according to DIN EN 673 $\Delta T = 15 \text{ K}$ in $W/(m^2 \cdot K)$
		construction in mm	filling rate in %	gas type	E^{**}	ϵ_n^*	
28	Guardian ClimaGuard™ Premium	4/12/4	90	70%Ar 30%SF ₆	2	0.03	1.5
29	Guardian ClimaGuard™ Premium	4/14/4	90	70%Ar 30%SF ₆	2	0.03	1.5
30	Guardian ClimaGuard™ Premium	4/16/4	90	70%Ar 30%SF ₆	2	0.03	1.5
31	Guardian ClimaGuard™ Premium	4/18/4	90	70%Ar 30%SF ₆	2	0.03	1.5
32	Guardian ClimaGuard™ Premium	4/20/4	90	70%Ar 30%SF ₆	2	0.03	1.6
33	Guardian ClimaGuard™ Premium	4/12/4	90	70%Ar 30%SF ₆	3	0.03	1.5
34	Guardian ClimaGuard™ Premium	4/14/4	90	70%Ar 30%SF ₆	3	0.03	1.5
35	Guardian ClimaGuard™ Premium	4/16/4	90	70%Ar 30%SF ₆	3	0.03	1.5
36	Guardian ClimaGuard™ Premium	4/18/4	90	70%Ar 30%SF ₆	3	0.03	1.5
37	Guardian ClimaGuard™ Premium	4/20/4	90	70%Ar 30%SF ₆	3	0.03	1.6
38	Guardian ClimaGuard™ Premium	4/12/4	90	Argon	2+3	0.03	1.2
39	Guardian ClimaGuard™ Premium	4/12/4	90	Krypton	2+3	0.03	1.0
40	Guardian ClimaGuard™ Premium	4/14/4	90	Krypton	2+3	0.03	1.0
41	Guardian ClimaGuard™ Premium	4/16/4	90	Krypton	2+3	0.03	1.0
42	Guardian ClimaGuard™ Premium	4/18/4	90	Krypton	2+3	0.03	1.1
43	Guardian ClimaGuard™ Premium	4/10/4/10/4	90	Argon	2+5	0.03	0.8
44	Guardian ClimaGuard™ Premium	4/12/4/12/4	90	Argon	2+5	0.03	0.7
45	Guardian ClimaGuard™ Premium	4/14/4/14/4	90	Argon	2+5	0.03	0.6
46	Guardian ClimaGuard™ Premium	4/16/4/16/4	90	Argon	2+5	0.03	0.6
47	Guardian ClimaGuard™ Premium	4/10/4/10/4	90	Krypton	2+5	0.03	0.6
48	Guardian ClimaGuard™ Premium	4/12/4/12/4	90	Krypton	2+5	0.03	0.5

E^* position of the coating

ϵ_n^* normal emissivity; source: measurement according to Pt. 2.2 at ift

1 Object

1.1 Description of test specimen (all dimensions in mm)

Product	Insulating glass unit (IGU)
Type	Guardian ClimaGuard® Premium
Construction	see type list
Coating	
Type / Manufacturer	Guardian ClimaGuard® Premium/ Guardian
Coating on surface	2, 3, 2+3, 2+5
normal emissivity ϵ_n	0,03
Source	test according to EN 12898
Gas filling in cavity	according to the customer
Gas type	see type list
Volume in %	see type list

The description is based on the documentation of **ift**. Numbers and names of material are given by the customer. (Further data from customer are marked with *).

1.2 Representation of test specimen

The illustration was produced by the **ift** as a schematic representation of the cross section.

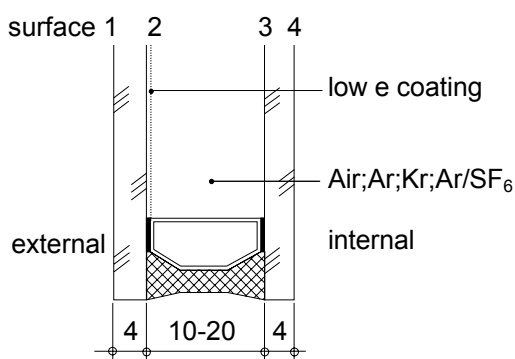

Figure 1 Representation of the system coating on surface 2

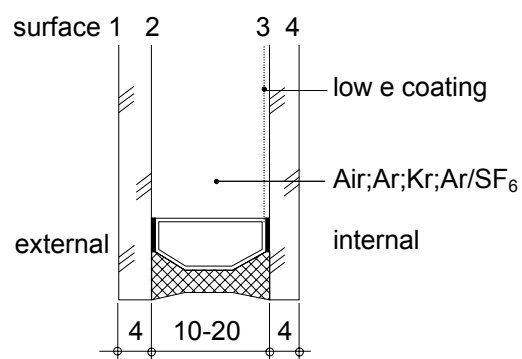

Figure 2 Representation of the system coating on surface 3

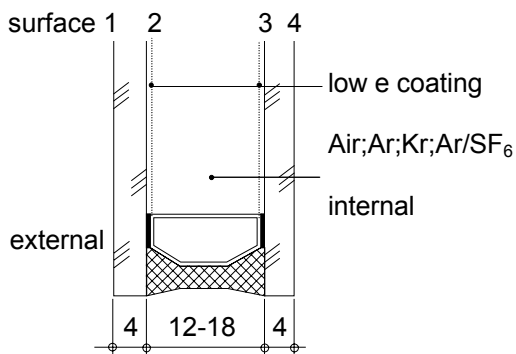

Figure 3 Representation of the system coating on surface 2+3

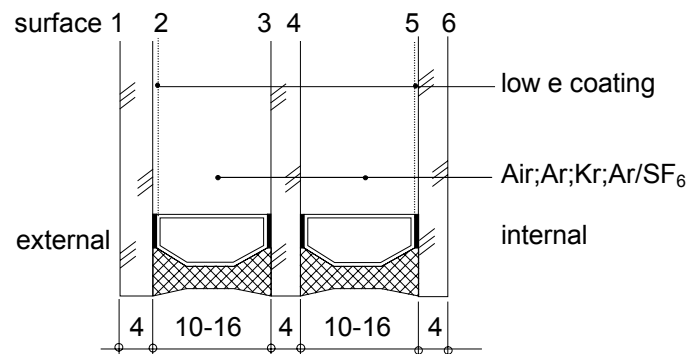

Figure 4 Representation of the system coating on surface 2+5

2 Procedure

2.1 Sampling

The specimen were selected by the customer.

Quantity	3
Delivered	18 January 2005 by the customer
Registry	679

2.2 Process

2.2.1 Determination of the emissivity

Technical basis

EN 12898 : 2001-01	Glass in building – Determination of the emissivity
EN 673 : 1997-11	Glass in building – Determination of thermal transmittance (U value) – Calculation method
+A1 : 2000-10	

Boundary conditions as required in the standard

Deviations There are no deviations from the test procedure or test conditions

2.2.2 Calculation of thermal transmittance

Technical basis

EN 673 : 1997-11

+A1 : 2000-10

Glass in building – Determination of thermal transmittance
(U value) – Calculation method

Boundary conditions

Inclination of glazing

 $\varepsilon_n = 0.89$ $\varepsilon = 0.837$ $h_e = 23 \text{ W/(m}^2\text{K)}$ $h_i = 8 \text{ W/(m}^2\text{K)}$

as required in the standard

vertical

normal emissivity of the room-facing surface

corrected emissivity of the room-facing surface

external heat transfer coefficient

internal heat transfer coefficient

Deviations

There are no deviations from the test procedure or test conditions

3 Detailed results

Table 1 Calculated thermal transmittance U_g for the following insulating glass units

	Type	Parameters for the calculation					U_g	
		construction in mm	gas filling in %	gas type	E^*	ε_n^{**}	calculated U_g - value according to EN 673 $\Delta T = 15 \text{ K}$ in $\text{W/(m}^2\text{K)}$	rounded $U_g^{(2)}$ -value according to EN 673 $\Delta T = 15 \text{ K}$ in $\text{W/(m}^2\text{K)}$
1	Guardian KlimaGuard™ Premium	4/12/4	-	Air	2	0.03	1.62	1.6
2	Guardian KlimaGuard™ Premium	4/14/4	-	Air	2	0.03	1.46	1.5
3	Guardian KlimaGuard™ Premium	4/18/4	-	Air	2	0.03	1.38	1.4
4	Guardian KlimaGuard™ Premium	4/20/4	-	Air	2	0.03	1.40	1.4
5	Guardian KlimaGuard™ Premium	4/12/4	-	Air	3	0.03	1.62	1.6
6	Guardian KlimaGuard™ Premium	4/14/4	-	Air	3	0.03	1.46	1.5
7	Guardian KlimaGuard™ Premium	4/16/4	-	Air	3	0.03	1.37	1.4
8	Guardian KlimaGuard™ Premium	4/18/4	-	Air	3	0.03	1.38	1.4
9	Guardian KlimaGuard™ Premium	4/20/4	-	Air	3	0.03	1.40	1.4
10	Guardian KlimaGuard™ Premium	4/12/4	90	Argon	2	0.03	1.28	1.3
11	Guardian KlimaGuard™ Premium	4/14/4	90	Argon	2	0.03	1.15	1.2
12	Guardian KlimaGuard™ Premium	4/16/4	90	Argon	2	0.03	1.13	1.1
13	Guardian KlimaGuard™ Premium	4/18/4	90	Argon	2	0.03	1.14	1.1
14	Guardian KlimaGuard™ Premium	4/20/4	90	Argon	2	0.03	1.15	1.2



	Type	Parameters for the calculation					U_g	
		construction in mm	gas filling in %	gas type	E^*	ϵ_n^{**}	calculated U_g - value according to EN 673 $\Delta T = 15 K$ in $W/(m^2K)$	rounded $U_g^{(2)}$ -value according to EN 673 $\Delta T = 15 K$ in $W/(m^2K)$
15	Guardian ClimaGuard™ Premium	4/20/4	91	Argon	2	0.03	1.15	1.1
16	Guardian ClimaGuard™ Premium	4/12/4	90	Argon	3	0.03	1.28	1.3
17	Guardian ClimaGuard™ Premium	4/14/4	90	Argon	3	0.03	1.15	1.2
18	Guardian ClimaGuard™ Premium	4/16/4	90	Argon	3	0.03	1.13	1.1
19	Guardian ClimaGuard™ Premium	4/18/4	90	Argon	3	0.03	1.14	1.1
20	Guardian ClimaGuard™ Premium	4/20/4	90	Argon	3	0.03	1.15	1.2
21	Guardian ClimaGuard™ Premium	4/20/4	91	Argon	3	0.03	1.15	1.1
22	Guardian ClimaGuard™ Premium	4/10/4	90	Krypton	2	0.03	1.04	1.0
23	Guardian ClimaGuard™ Premium	4/12/4	90	Krypton	2	0.03	1.07	1.1
24	Guardian ClimaGuard™ Premium	4/16/4	90	Krypton	2	0.03	1.10	1.1
25	Guardian ClimaGuard™ Premium	4/10/4	90	Krypton	3	0.03	1.04	1.0
26	Guardian ClimaGuard™ Premium	4/12/4	90	Krypton	3	0.03	1.07	1.1
27	Guardian ClimaGuard™ Premium	4/16/4	90	Krypton	3	0.03	1.10	1.1
28	Guardian ClimaGuard™ Premium	4/12/4	90	70%Ar 30%SF ₆	2	0.03	1.48	1.5
29	Guardian ClimaGuard™ Premium	4/14/4	90	70%Ar 30%SF ₆	2	0.03	1.50	1.5
30	Guardian ClimaGuard™ Premium	4/16/4	90	70%Ar 30%SF ₆	2	0.03	1.52	1.5
31	Guardian ClimaGuard™ Premium	4/18/4	90	70%Ar 30%SF ₆	2	0.03	1.54	1.5
32	Guardian ClimaGuard™ Premium	4/20/4	90	70%Ar 30%SF ₆	2	0.03	1.56	1.6
33	Guardian ClimaGuard™ Premium	4/12/4	90	70%Ar 30%SF ₆	3	0.03	1.48	1.5
34	Guardian ClimaGuard™ Premium	4/14/4	90	70%Ar 30%SF ₆	3	0.03	1.50	1.5
35	Guardian ClimaGuard™ Premium	4/16/4	90	70%Ar 30%SF ₆	3	0.03	1.52	1.5
36	Guardian ClimaGuard™ Premium	4/18/4	90	70%Ar 30%SF ₆	3	0.03	1.54	1.5
37	Guardian ClimaGuard™ Premium	4/20/4	90	70%Ar 30%SF ₆	3	0.03	1.56	1.6

	Type	Parameters for the calculation					U_g	
		construction in mm	gas filling in %	gas type	E^*	ϵ_n^{**}	calculated U_g - value according to EN 673 $\Delta T = 15 K$ in $W/(m^2K)$	rounded $U_g^{(2)}$ -value according to EN 673 $\Delta T = 15 K$ in $W/(m^2K)$
38	Guardian ClimaGuard™ Premium	4/12/4	90	Argon	2+3	0.03	1.23	1.2
39	Guardian ClimaGuard™ Premium	4/12/4	90	Krypton	2+3	0.03	1.01	1.0
40	Guardian ClimaGuard™ Premium	4/14/4	90	Krypton	2+3	0.03	1.02	1.0
41	Guardian ClimaGuard™ Premium	4/16/4	90	Krypton	2+3	0.03	1.04	1.0
42	Guardian ClimaGuard™ Premium	4/18/4	90	Krypton	2+3	0.03	1.05	1.1
43	Guardian ClimaGuard™ Premium	4/10/4/10/4	90	Argon	2+5	0.03	0.83	0.8
44	Guardian ClimaGuard™ Premium	4/12/4/12/4	90	Argon	2+5	0.03	0.72	0.7
45	Guardian ClimaGuard™ Premium	4/14/4/14/4	90	Argon	2+5	0.03	0.64	0.6
46	Guardian ClimaGuard™ Premium	4/16/4/16/4	90	Argon	2+5	0.03	0.58	0.6
47	Guardian ClimaGuard™ Premium	4/10/4/10/4	90	Krypton	2+5	0.03	0.56	0.6
48	Guardian ClimaGuard™ Premium	4/12/4/12/4	90	Krypton	2+5	0.03	0.49	0.5

E^* position of the coating

ϵ_n^* normal emissivity; source: measurement according to Pt. 2.2 at ift

1) U_g -value rounded to three significant figures

2) U_g -Wert rounded according to EN 673

ift Rosenheim

8 March 2005